

TFC - Thunderbird District Roundtable.



THE OCTOBER 2008 CUB SCOUT MONTHLY THEME IS:

“ADVENTURE IN BOOKS”

OFFICIAL BSA THEME DESCRIPTION:



“What great adventures come in books? Let's discover some this month. Visit the library and learn to navigate your way through the "card catalog computer," down the aisles of many adventures, and to an adventure of your own choice. Sign up for your library card while on your visit. Create your own outdoor epic adventure on a hike, campout, or maybe at a ball field or park. Make a costume for one of the characters from your favorite story. At the pack meeting the boys can perform some of their favorite stories and share some of their adventures with the pack. Take part in Pedro's "Say Yes to Reading" program in Boy's Life. This might also be a good month to work on the Communication or Computer belt loop and pin. Encourage the boys to have the courage to search for, discover, and share adventure this month.”

“ADVENTURE IN BOOKS” ACHIEVEMENTS AND ELECTIVES

TIGERS:

Achievement 1G – Go to the library.

Achievement 3G - Learn the rules of a game or sport. Then, go watch an amateur or professional game or sporting event.

Elective 14 –With your adult partner, read a short story or magazine article. If you read a book and enjoy it, enter the Boy's Life Reading contest!

WOLVES:

Achievement 1 – See if any of the Feats of Skill remind you of characters in a book and do the actions;

Achievement 2d – find a book that tells about your state and its flag;

Achievement 7e – find and read three stories about how people are protecting our world;

Achievement 10d – Read a book or Boy's Life magazine – enter the Boy's Life reading contest;

Elective 6 – Books, Books, Books;

Elective 10F - Learn 12 American Indian word pictures and write a story with them.

Elective 22c – read a story in Boy's Life or another magazine and tell it to your den, den leader or an adult;

BEARS:

Achievements 1b and 2 – explore how special books or religious texts are used in your religion and do required reading;

Achievement 3b – Learn about two famous Americans in books, tell the things they did or are doing to improve our way of life.

Achievement 3e – use a reference book to find out about a state;

Achievement 4c – Read two folklore stories and tell your favorite one to your den.

Achievement 5a – read a book about a bird or other animal, then make a poster;

Achievement 23a - Learn the rules of and how to play three team sports.

Achievement 23b - Learn the rules of and how to play two sports in which only one person is on each side.

Elective 24a – learn about local Native Americans to your area using a book.



With October's theme Adventures in Books, it may be a good month for your den or pack to make a field trip to your local library. A tour can with earning rank badge achievement or electives for Tigers, Wolves and Bears.



This month would be a great time to begin work on the BSA Family Award, as families read together each night. The major goals of this program are to strengthen families and to encourage family involvement in Scouting.

See: [www.scouting.org/CubScouts/Awards/Boys/The BSA Family Award.aspx](http://www.scouting.org/CubScouts/Awards/Boys/The_BSA_Family_Award.aspx)

Also See: <http://www.geocities.com/~pack215/bsafamily.html#introduction>

BOYS' LIFE 2008 "SAY YES TO READING!" CONTEST.

Write a one-page report titled "The Best Book I Read This Year" and enter it in the Boys' Life 2008 "Say Yes to Reading!" contest.

The book can be fiction or nonfiction. But the report has to be in your own words — 500 words tops. Enter in one of these three age categories:

- 8 YEARS OLD AND YOUNGER
- 9 AND 10 YEARS OLD
- 11 YEARS OLD AND OLDER

First-place winners in each age category will receive a \$100 gift certificate good for any product in the Boy Scouts official retail catalog. Second-place winners will receive a \$75 gift certificate and third-place winners a \$50 certificate.

Everyone who enters will get a free patch like the one on this page. (And, yes, the patch is a temporary insignia, so it can be

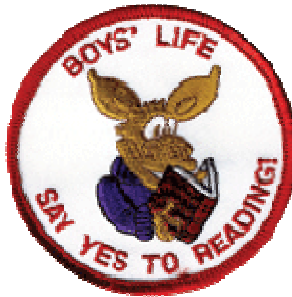

worn on the Boy Scout uniform shirt, on the right pocket. Proudly display it there or anywhere!) In coming years, you'll have the opportunity to earn different patches.

The contest is open to all Boys' Life readers. Be sure to include your name, address, age and grade in school on the entry.

Send your report, along with a business-size, self-addressed, stamped envelope, to:

BOYS' LIFE READING CONTEST
S306
P.O. BOX 152079
IRVING, TX 75015-2079

Entries must be postmarked by **Dec. 31, 2008** and must include entry information and a self-addressed, stamped envelope.

THE SEPTEMBER ROUNDTABLE "BY REQUEST" DEMONSTRATIONS ARE:

"CUBMOBILE AND KNOTS"

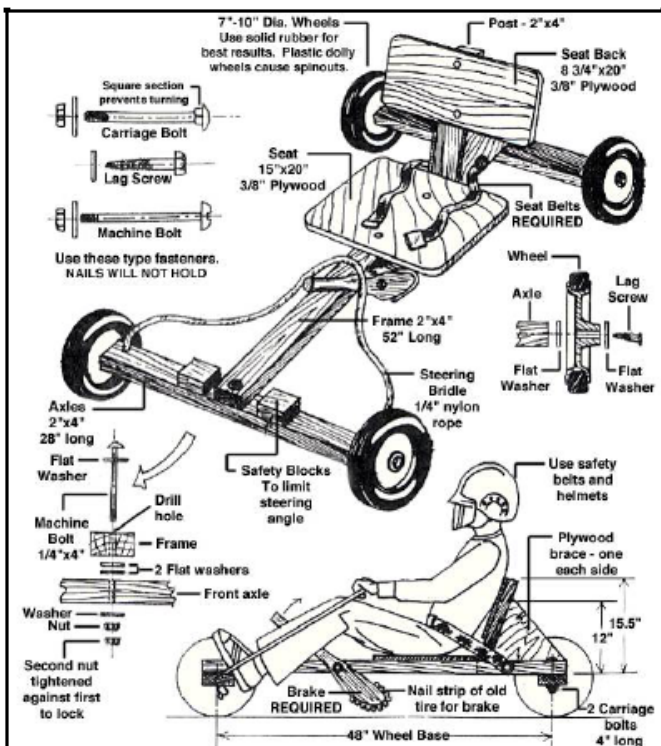

By Request, Roundtable staff will provide detail instruction and guide den leaders on how to assemble a Cubmobile. We will also review a great resource to help learn how to tie knots available at the Boys' Life website.

<http://www.carypack457.org/forms/Cubmobile.pdf>

<http://www.boyslife.org/about-scouts/large-width/644/learn-to-tie-knots/>

THREE FIRES COUNCIL READING PROGRAM



This is a year-round program to promote reading. Reading dates are from September 1 – August 31st. This is a Council wide award program to recognize Scouts and their families for spending time reading. The reader keeps a log of reading time. For every 500 minutes of reading time, they earn recognition.

The reading requirements are as follows: All reading materials pertinent to the values of Scouting. This could be books, magazines or newspaper articles. Reading time is not limited to reading on your own. The time spent reading to or with others, i.e. parents, siblings, grandparents, anyone else, counts towards the total. There are many opportunities for various reading projects. This program is open to everyone!

For the first 500 minutes, the reader would earn the initial starting 3" patch for the reading program. This price for this patch is \$3. With each additional 500 minutes they would earn a reading program segment patch to go around the big patch at \$0.50 each.

3" Starting patch for the first 500 minutes

500 minutes of general reading – Book segment #72

Subscribed to Boy's Life magazine and 500 minutes reading it – Boy's Life segment #56

500 minutes of family reading - Family segment #199

500 minutes reading to sick/disabled/shut-ins - Good Turn segment #201

500 minutes of reading religious materials – Religious segment #2(church)____, #4(religious)____, #5(praying hands)____, or #159(Christian: fish)____

Visit to Newspaper office and read newspaper– Newspaper segment #115

500 minutes reading about nature/conservation – Nature segment #167

500 minutes reading about Sports/Fitness – Sports segment #66____, or Fitness segment #65____

Wrote 8 Pen Pal letters or Thank You notes for popcorn sales– Stamp/Envelope segment #187

NEXT MONTH'S THEME: SEEDS OF KINDNESS.

As we approach Thanksgiving, let us spread seeds of kindness in the form of multiple small service projects. Helping others gives the boys the opportunity to see the bounty produced by spreading many small seeds of kindness and encourages compassion. The boys can discover that just as the large strong oak tree came from the small acorn, big things can happen from spreading small seeds of kindness and charity. Conduct a food drive or collect coats and gloves for those in need; report your hours to Good Turn for America. Work on the Citizenship belt loop and pin.

HOW TO BUILD A CUBMOBILE

Detailed Instructions: If you wish to build the cubmobile illustrated, these are step by step instructions. Have Fun!!!

1. Cut one 2 X 4 52" for main frame.
2. Cut two 2 X 4's 28" for axles.
3. Make an "X" on each end of each axle, and drill a hole at each "X" intersect, 6" deep using a hand electric drill (5/16" wood bit works well).
4. On front axle 2 X 4:
 - a. Drill a 5/16" hole on each end near the back for the rope.
 - b. Drill a 3/8" hole at center of 2 X 4.
 - c. Attach (2) 2 X 4 blocks to front axle, on either side, 2-1/8" from center hole, use glue and #6 X 2" screws. This will limit steering.

HOW TO BUILD A CUBMOBILE CONTINUED

5. At front of main frame 2 X 4, drill a 3/8" hole (center 1-5/8" from front).
6. Attach front axle to frame using 3/8" X 4" hex bolt, 4 washers, and lock nut or 2 nuts. (Tighten enough to allow steering).
7. Align back axle 2 X 4 at right angle with back of main frame 2 X 4, clamp if possible. Drill (2) 5/16" holes through axle and main frame. Attach main frame to back axle using 2 carriage bolts, 2 washers, 2 lock washers, and 2 nuts. If this is to be a permanent attachment, glue also.
8. Cut out seat and back rest from plywood.
9. Cut one 2 X 4 12-14" in length for back rest support. (Bevel slightly about 5 degrees if possible).
10. Attach back rest support (bevel end down) to main frame using glue and 2 screws (#8...2-1/2") at an angle. Position of this support depends on size of boy, have scout sit on 2 X 4 frame to estimate position.
11. Cut out 2 triangular shaped pieces of plywood and attach to either side of backrest support and main frame with glue and screws (#6 1-1/2"). Drilling small pilot holes helps.
12. Attach seat and back rest using glue and screws (#6...1-1/2").
13. Cut 2 X 2 surveyor's stake to 14-16" at an angle, cover end with rubber using nails, drill a 3/8" hole through stake at location it will meet main frame.
14. Drill hole 5/16" into main frame at point to attach brake. Mount brake using 3/8" X 4" lag screw and washer to side of main frame.
15. Drill and attach seat belt with fasteners of choice.
16. Attach 6-7' of 1/4" rope to front axle as shown.
17. Attach wheels using washers and 3/8" X 6" lag screws. (Socket wrench helps).

SUPPLIES

4 - 8" wheels	1 - 3/8" lock nut
1 - 2'X4' 3/8" or 1/2" plywood	2 - 5/16" washers
2 - 8' 2X4's	2 - 5/16" lock washers
1 - 2"X2" surveyor's stake	2 - 5/16" nuts
4 - 3/8" X 6" lag screws (for wheels)	32 - #6 X 1 1/2" wood screws
1 - 3/8" X 4" hex bolt (for front axle)	4 - #6 X 2" wood screws
1 - 3/8" X 4" lag screw (for brake)	1 - 6-7' 1/4" rope
2 - 5/16" X 4" carriage bolts (for rear axle)	1 - seat belt (from salvage yard)
13 - 3/8" washers	1 - 2" X6" piece of rubber (from old tire)

TOOLS

Power drill	Tape measurer
3/8" and 5/16" wood bit	Wood glue (optional)
Wrenches or socket set	Power or hand saw
Screwdriver	Rasp and Sand Paper (60 to 100 Grit)

7"-10" Dia. Wheels
Use solid rubber for best results. Plastic dolly wheels cause spinouts.

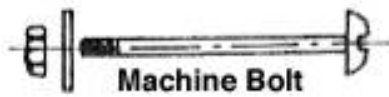
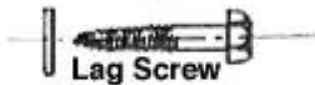
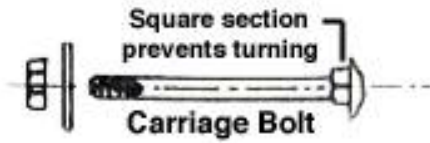

Use these type fasteners.
NAILS WILL NOT HOLD

Post - 2"x4"

Seat Back
8 3/4"x20"
3/8" Plywood

Seat
15"x20"
3/8" Plywood

Seat Belts
REQUIRED

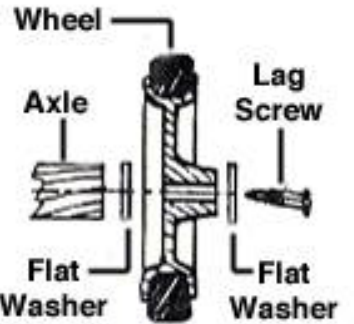

Frame 2"x4"
52" Long

Steering
Bridle
1/4" nylon
rope

Axles
2"x4"
28" long

Safety Blocks
To limit
steering
angle

Use safety
belts and
helmets

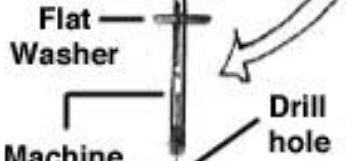

Drill hole
Frame

2 Flat washers

Front axle

Plywood
brace - one
each side

Washer
Nut

Second nut
tightened
against first
to lock

15.5"
12"

Brake
REQUIRED
Nail strip of old
tire for brake

2 Carriage
bolts
4" long

48" Wheel Base

